

DC12-120 Product Data Sheet

Issue Date: 21/07/2022

Issued By: R & J Batteries PTY LTD

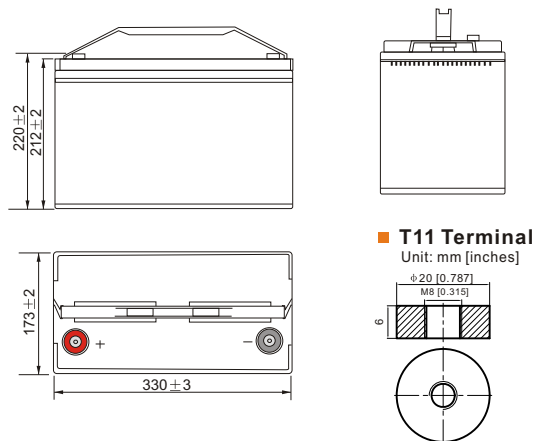

Specifications:

Model: DC12-120	
Nominal Voltage	12V
Rated Capacity	
20 Hour Rate (6.00A to 10.8V)	120.0Ah
Hourly rate conversion capacity	
10 Hour Rate (11.2A to 10.8V)	112.0Ah
5 Hour Rate (19.6A to 10.5V)	98.0Ah
1 Hour Rate (67.5A to 9.6V)	67.5Ah
Dimension and Weight	
Length	330±2mm
Width	173±2mm
Height	212±2mm
Total Height	220±2mm
Weight	31.2Kg
Casing Material	ABS
Self discharge Rate (25°C)	≥91% /3 month
Internal Resistance	Fully charged Battery ≤ 4.5mΩ
Operating Temperature Range	
Discharge	-15°C (5°F) ~ 50°C(122°F)
Charge	0 °C(32°F) ~ 40°C(104°F)
Storage	-15°C(5°F)~40°C(104°F)
Charging Methods	
Float Use	13.5V~13.8V(25°C), Compensation co-efficient-3mv/cell/°C
Cycle Use	14.4V~14.7V(25°C), Compensation co-efficient-5mv/cell/°C
Max. Charge Current	0.25C (30A)
Applications:	Electric vehicle, solar power, wind power, telecom systems, UPS, Medical, Toys

Discharge Characteristics

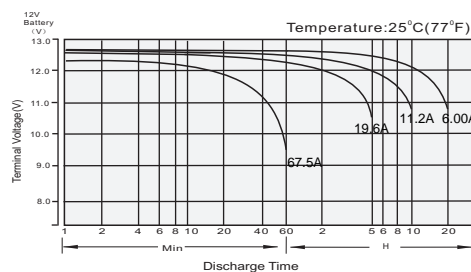

Cycle Life in Relation to Depth of Discharge

